

2017

Performance Degradation Analysis of Aviation Hydraulic Piston Pump Based on Mixed Wear Theory

C. Zhang

S. Wang

M. Tomovic

Old Dominion University, mtomovic@odu.edu

L. Han

Follow this and additional works at: https://digitalcommons.odu.edu/engtech_fac_pubs

 Part of the [Aerospace Engineering Commons](#)

Repository Citation

Zhang, C.; Wang, S.; Tomovic, M.; and Han, L., "Performance Degradation Analysis of Aviation Hydraulic Piston Pump Based on Mixed Wear Theory" (2017). *Engineering Technology Faculty Publications*. 25.
https://digitalcommons.odu.edu/engtech_fac_pubs/25

Original Publication Citation

Zhang, C., Wang, S., Tomovic, M., & Han, L. (2017). Performance degradation analysis of aviation hydraulic piston pump based on mixed wear theory. *Tribology in Industry*, 39(2), 248-254. doi:10.24874/ti.2017.39.02.12

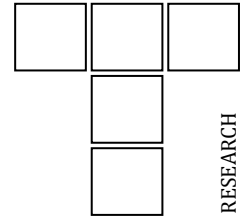

Performance Degradation Analysis of Aviation Hydraulic Piston Pump Based on Mixed Wear Theory

C. Zhang^a, S. Wang^a, M. Tomovic^b, L. Han^c

^a School of Automation Science and Electrical Engineering, Beihang University, China,

^b Department of Engineering Technology, Old Dominion University, USA,

^c School of Automation, Beijing University of Posts and Telecommunications, China.

Keywords:

Axial piston pump
Mixed wear
Performance degradation
Cylinder block
Valve plate

ABSTRACT

This paper focuses on the mathematical modeling of axial piston pump through dividing the failure development of friction pair into lubrication, mixed lubrication and abrasion. Directing to the wedge-shaped oil film between cylinder block and valve plate, the support force distribution under the temperature variance was obtained. Considering the rough peak of valve plate, the contact load model is built under plastic deformation and elastic deformation and the corresponding wear volume is calculated. Computing the wear and tear along the counter-clockwise, the total amount of friction and wear can be calculated. Simulation and preliminary wear particle monitoring test indicates that proposed modeling and analysis can effectively reflect the real abrasion process of hydraulic piston pump.

Corresponding author:

Chao Zhang
Beihang University, 303,
37 Xueyuan Road, Haidian District,
Beijing, 100191, China.
E-mail: czhangstar@gmail.com

© 2017 Published by Faculty of Engineering

1. INTRODUCTION

Aviation axial piston pump provides pressurized fluid to drive aircraft systems such as surface control system, landing gear system and nose wheel steering system. With the high efficiency and high power to weight ratio, axial piston pumps are widely used in aircraft. However, the structure of axial piston pumps is usually complicated, which makes it easy to fail due to the wear and tear of internal friction pairs. Based on the statistics, more than 70% failures of axial piston pump is the leakage due to the wear and tear of main friction pairs [1]. So many researches carried out the research on the failure mechanism under dynamic lubrication and abrasive wear.

The main friction pairs of axial piston pump consist of cylinder block/valve plate, piston/plunger chamber and piston shoes/swash plate. Generally, the main friction pairs operate in good lubrication condition. However, as the operational principle of axial piston pumps is usually complicated, it could easily go into boundary lubrication, or even abrasion, so the wear and tear plays major role in the failure of axial piston pumps. Research on axial piston pumps related to failure analysis can be divided into two types: one focuses on the lubrication, while the other emphasizes on the wear and tear. In 1986, Yagaguchi studied the lubrication between the valve plate and cylinder block, and gives the mathematical model of fluid

oil [2]. Based on above model, he established the dynamic model of cylinder block, calculated its force and torque, and provided the stable condition of constant oil film between the valve plate and the cylinder barrel [3]. Through fixing up the displacement sensors along the valve plate, the oil film thickness distribution between the valve plate and the cylinder block was obtained [3]. In order to get the variation of oil film, Maring measured the oil film pressure between piston shoes and swash plate through experiment [4]. At the same time, Ivantysynova established the oil film model of cylinder block and valve plate considering the elastic deformation of the contact surface under high pressure [5]. She also analyzed the temperature influence between this friction pair considering the effects of viscosity and pressure change [6][7]. With the continuous operation of the axial piston pump, Greenwood and Williamson discovered the local contact when the oil film thickness is smaller than the roughness of the two surfaces, and built the Greenwood-Williamson model based on the elastic contact of rough surfaces [8]. In order to connect the bridge between the lubrication and abrasion of friction pairs, Patir and Cheng proposed a kind of Reynolds equation to solve the lubrication problem under local contact condition for the axial piston pump [9][10]. Yamaguchi analyzed the mixed lubrication based on Greenwood-Williamson model and Patir equation and built the test rig [11]. The corresponding experiment indicated that the proposed model can give the predict friction force and flow rate. Subsequently, many researches presented a series models to describe the multi scale characteristics of rough peak curvature in two surface contact [12][13]. Majumdar and Bhushan established the classification model of elastic plastic contact process on the rough peak, in which the plastic deformation connect is considered as connected to each other can be further treated as elastic state [14]. Considering the rough peak deformation, Liou proposed a contact model based on height distribution of non Gauss distribution [15].

This paper establishes the mixed wear model considering the lubrication, boundary lubrication and abrasion, provides the performance degradation law and gives the estimation based on the online wear debris monitoring.

The rest of this paper is organized as follows. Section 2 presents the mixed wear theory based on the lubrication, boundary lubrication and abrasion. Section 3 provides the performance degradation due to the wear and tear of the friction pairs. Section 4 shows the experimental results through online contamination monitoring. The conclusions are in Section 5.

2. MIXED WEAR MODELING OF AXIAL PISTON PUMP

Figure 1 shows the structure of axial piston pump, in which the valve plate and swash plate are fixed, the shaft drives the cylinder block and the pistons reciprocate in it when the axial piston pump is operating. There are three friction pairs in axial piston pump, that is, cylinder block/valve plate, slipper/swash plate and piston/plunger cavity. The cylinder block-valve plate plays an important role in axial piston pump because its failures predominate in maintenance.

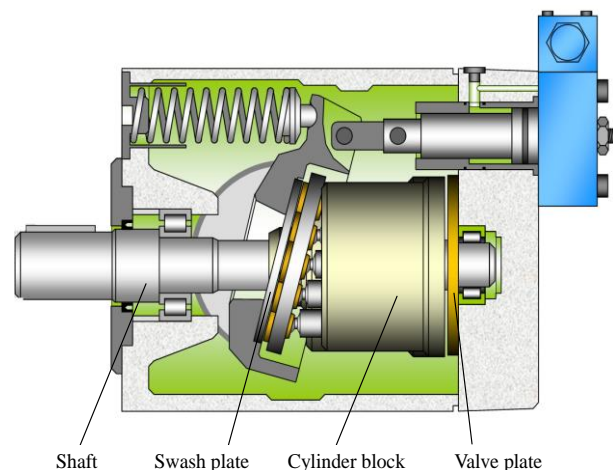

Fig. 1 The structure of axial piston pump.

Through analyzing the surface morphology of the worn valve plate, its eccentric wear in high pressure area occupies the primary position. Since the axial piston pump is full of oil, its normal operation depends on the lubrication between friction pairs. Based on the tribology theory, most of the abrasive wear of the axial piston pump is caused by lack of oil film between friction pair surfaces. In order to describe the failure development of abrasive wear, it is necessary to investigate the dynamic variation of the fluid film and abrasion rule between valve plate and cylinder block.

2.1 Dynamic lubrication model of cylinder block and valve plate

Since the imbalance pressure distribution between cylinder block and valve plate, the oil film between the friction pair is wedge-shaped, as shown in Fig. 2.

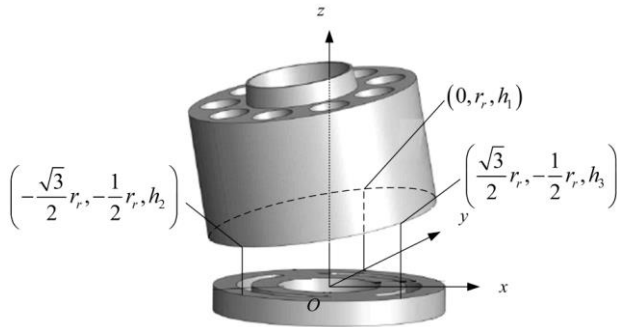

Fig. 2. Wedge-shaped oil film between cylinder block and valve plate.

For wedge-shaped oil film, the position of the whole cylinder block can be determined through measuring the height of 3 fixed points. Generally, the oil film thickness at any point can be determined as follows:

$$h(x, y) = \frac{h_3 - h_2}{\sqrt{3}r_r} x + \frac{2h_1 - h_2 - h_3}{3r_r} y + \frac{h_1 + h_2 + h_3}{3} \quad (1)$$

where (x, y) is the coordinate at arbitrary point of valve plate, r_r is reference radius, h_1, h_2 and h_3 are the height of oil film in the distributed three points of valve plate. According to the Reynolds equation, the relationship of support force and velocity can be described as:

$$\frac{\partial}{\partial x} \left(\frac{\rho h^3}{\mu} \frac{\partial p_l}{\partial x} \right) + \frac{\partial}{\partial y} \left(\frac{\rho h^3}{\mu} \frac{\partial p_l}{\partial y} \right) = 6 \left[\frac{\partial}{\partial x} (v_x \rho h) + \frac{\partial}{\partial y} (v_y \rho h) + 2\rho \frac{\partial h}{\partial t} \right] \quad (2)$$

where p_l is the support force of oil film, h is oil thickness, μ is dynamic viscosity, which is related to the temperature and pressure.

2.2 Partial abrasion analysis of cylinder block and valve plate

Under ideal condition, there exists a layer of oil film between valve plate and cylinder block, which plays the role of lubricating the operation of the friction pair shown in Fig. 3. Since the sealing strips separates the higher pressure area of outlet and lower pressure area of inlet, the periodic eccentric moment inevitably exists in

valve plate to cause out-of-balance between downward compressive stress F_B and upward support F_f . Then the cylinder block will contact the partial area of valve plate and cause the wear and tear.

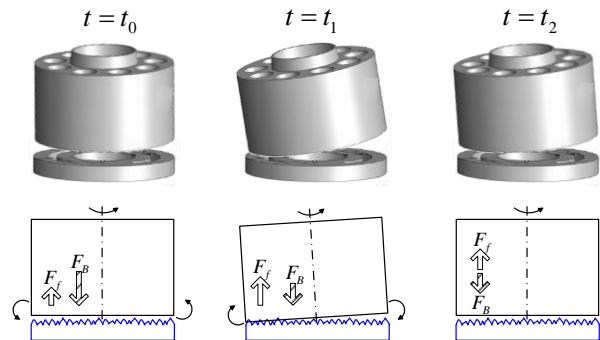

Fig. 3. Friction pair of cylinder block and valve plate.

In order to describe the contact of cylinder block and valve plate, Fig. 4 enlarges the contact surface, in which $R(\alpha)$ indicates the radius of curvature of rough peak and $g(z)$ illustrates the height distribution.

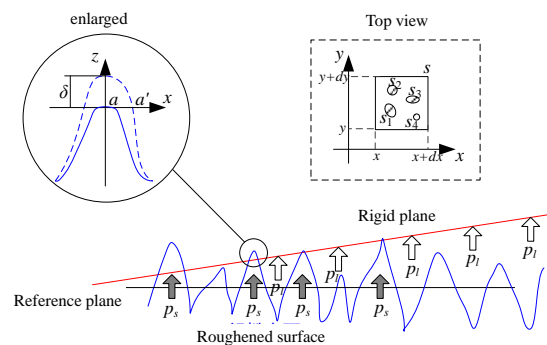

Fig. 4. Mixed lubrication state.

Assume the contact surface between cylinder block and valve plate has the following characteristics:

- 1) The surface of cylinder block is ideal rigid smooth plane;
- 2) The surface of valve plate is non-rigid rough surface;
- 3) The top of the rough peak on a rough surface is nearly half spherical;
- 4) The curvature of rough peak R is related to the sectional area of rough peak α ;
- 5) The upward support force of rough peak is p_s and oil film support force is p_l .

According to the Hertz contact theory, the critical deformation area of rough peak can be described as:

$$a_c = \pi \left(\frac{\pi H}{2E} \right)^2 R^2(a) \quad (3)$$

where H is material hardness, E is equivalent elastic modulus. When $a > a_c$, the contact asperity is elastic deformation. Otherwise, the contact asperity is plastic deformation.

When the contact asperity is in elastic deformation, the deflection can be described as:

$$\delta_e = \frac{a}{\pi R(a)} \quad (4)$$

Here $R(a)$ is complex curvature radius of rough peak.

Then the contact force of elastic deformation asperity is:

$$f_e(a) = \frac{4}{3} ER^{1/2}(a) \delta^{3/2} = \frac{4Ea^{3/2}}{3\pi^{3/2}R(a)} \quad (5)$$

When the contact asperity is the plastic deformation, the deflection can be obtained according to the volume conservation as:

$$\delta_p = \frac{\delta_c(a)}{2} + \frac{a}{2\pi R(a)} \quad (6)$$

The asperity contact area distribution of plastic deformation is shown as follows:

$$n_p(a) = \frac{A_a g(h)}{\pi a R(a)} \left[\frac{\pi \left(\frac{\pi H}{2E}\right)^2 R(a)}{2} \times \frac{dR(a)}{da} + \frac{1}{2} \left(1 - \frac{a}{R(a)} \times \frac{dR(a)}{da} \right) \right] \quad (7)$$

where A_a is real contact area, $g(h)$ is the integrated surface height distribution of rough peak. The plastic deformation contact force is:

$$f_p(a) = Ha \quad (8)$$

Then the contact load can be expressed as [14]:

$$p_s(x, y) = \int_0^{a_c} f_p(a) n_p(a) da + \int_{a_c}^{a_L} f_e(a) n_e(a) da \quad (9)$$

where a_c is critical deformation area, a_L is maximum asperity contact area, n_p is asperity contact area probability density function of plastic deformation, and n_e is asperity contact area probability density function of elastic deformation.

Based on Eq. (3) to Eq. (9), the pressure distribution of contact zone can be calculated.

2.3 Abrasive wear model of cylinder block and valve plate

If the eccentric wear between cylinder block and valve plate causes the particle and the particle

size to be larger than oil film, the abrasive wear will appear.

Assuming that the particle hardness is much higher than hardness of sliding surfaces, then the depth of a single abrasive particle embedded in the cylinder block and valve plate can be given by:

$$\begin{cases} \Delta_A(x, y, D) = \frac{H}{1+H} \left(\frac{D}{\tan \beta_d} - h(x, y) \right) \\ \Delta_B(x, y, D) = \frac{1}{1+H} \left(\frac{D}{\tan \beta_d} - h(x, y) \right) \end{cases} \quad (10)$$

where Δ_A is the depth of a abrasive particle embedded in the cylinder block, Δ_B is the depth of a abrasive particle embedded in the valve plate, D is the particle major axis, β is the angle to describe particle's shape, h is the separation of the surfaces, and H is the hardness ratio of valve plate versus cylinder block. Then we can get the wear volume of an abrasive particle in a certain time as:

$$\begin{cases} \Delta V_A(x, y, D) = f \Delta_A^2(x, y, D) \tan \beta_d \omega r(x, y) \\ \Delta V_B(x, y, D) = f \Delta_B^2(x, y, D) \tan \beta_d \omega r(x, y) \end{cases} \quad (11)$$

where f is coefficient of wear, ω is velocity of pump, r is the radius at point (x, y) . The total wear volume of friction pair within a certain period of time can be described as:

$$v = \iint_{(x,y) \in \Omega} [V_A(x, y) + V_B(x, y)] \quad (12)$$

where Ω is the abrasive wear region.

In order to calculate the wear and tear along the circle of valve plate, the start angle is $\varphi = 0$ and the positive direction is counter-clockwise. Then we can get the flow chat to calculate the oil film and wear volume, as shown in Fig. 5.

3. SIMULATION AND VALIDATION

The rated velocity of pump is 4000rpm, so we increase the angle from zero to 4000rpm and compute the oil film thickness distribution along the valve plate, the result is shown in Fig. 6.

Figure 6 shows that the oil film thickness is dependent with both time dependent and angle position. The oil film thickness decreases from

discharge port (150°) to inlet port (330°). The average film thickness of inner sealing strip is smaller than that of outer sealing strip in the

angular range of 60° to 240°. The simulation results demonstrate good agreement with the results in [16].

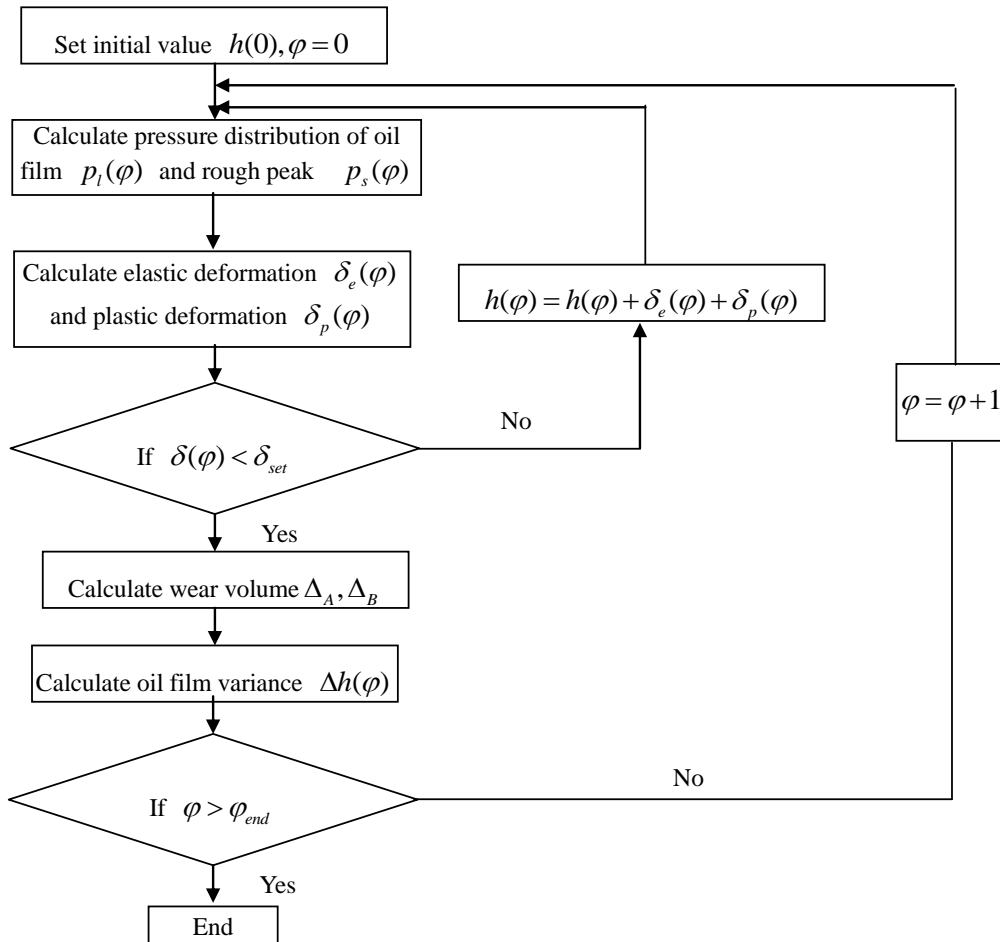
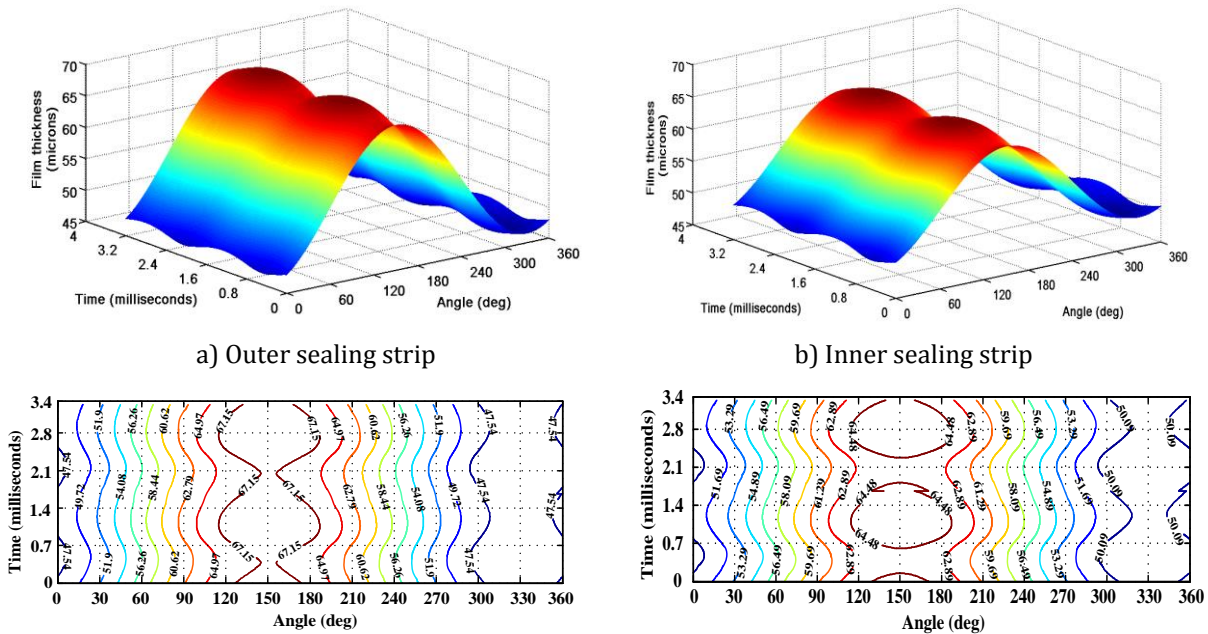

Fig. 5. Wear calculation under mixed lubrication condition.



c) Oil film thickness distribution of outer sealing strip

d) Oil film thickness distribution of inner sealing strip

Fig. 6. Dynamic oil film thickness of valve plate.

With the inductive debris sensor designed by our lab [17], we can detect the abrasive particle, as shown in Fig. 7.

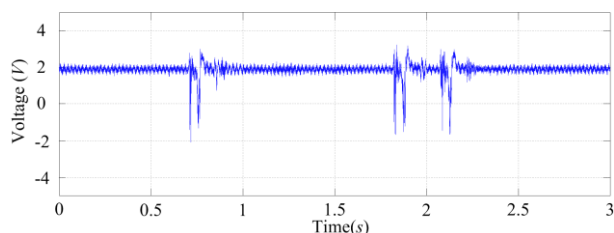

Fig. 7. The abrasive particle measured by inductive debris sensor.

The pulses in Fig.7 show that the wear particles are produced due to the wear and tear between cylinder block and valve plate. As the time goes on, the wear particles will accumulate and lead to the leakage shown in Fig. 8.

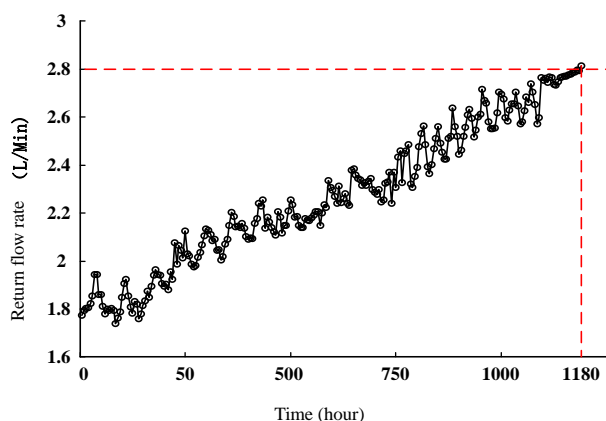

Fig. 8. Return flow rate of axial piston pump.

It is obvious that the return flow rate increases with the time, which means the wear and tear will increase and cause more leakage.

4. CONCLUSIONS

This paper studies the performance degradation based on the complicated failure process including lubrication, mixed lubrication and abrasion. Based on Reynolds equation and Hertz abrasion theory, this paper establishes the dynamic abrasive wear model of cylinder block and valve plate from normal lubrication, partial abrasion to wear and tear. Simulation and validation indicate that the proposed mathematical model can reflect the integrated failure development process of axial piston pump, and the performance degradation analysis result based on this model is more consistent with the actual application.

Acknowledgment

The authors would like to appreciate the support of National Basic Research Program of China (973 Program) (2014CB046402), Natural Science Foundation of China (51620105010, 51575019, 51505015) and Program111 of China.

REFERENCES

- [1] S. Wang, M. Tomovic and Hong Liu: *Commercial Aircraft Hydraulic Systems*, Academic Press of Elsevier, 2016.
- [2] A. Yamaguchi, 'Formation of A Fluid Film Between A Valve Plate And A Cylinder Block of Piston Pumps And Motors: 1st Report, A Valve Plate With Hydrodynamic Pads', *Bulletin of Jsme*, vol. 29, no. 251, pp. 1494-1498, 1986.
- [3] A. Yamaguchi, 'Formation of A Fluid Film Between A Valve Plate And A Cylinder Block of Piston Pumps And Motors. (2nd Report a Valve Plate With Hydrostatic Pads', *Jsm International Journal*, vol. 30, no. 259, pp. 87-92, 1987.
- [4] N.D. Manring, 'Friction Forces Within The Cylinder Bores of Swash-Plate Type Axial-Piston Pumps And Motors', *Journal of Dynamic Systems, Measurement and Control*, vol. 212, no. 3, pp. 531-537, 1999.
- [5] M. Ivantysynova and R. Lasaar, 'An Investigation Into Micro-And Macrogeometric Design of Piston/Cylinder Assembly of Swash Plate Machines', *International Journal of Fluid Power*, vol. 5, no. 1, pp. 23-36, 2004.
- [6] C. Huang and M. Ivantysynova, 'A New Approach To Predict The Load Carrying Ability of the Gap Between Valve Plate And Cylinder Block', *Bath Workshop on Power Transmission and Motion Control*, pp. 225-240, 2003.
- [7] N. Jouini and M. Ivantysynova, 'Valve Plate Surface Temperature Prediction in Axial Piston Machines', in: *Proceedings of the 5th Fpni Phd Symposium*, Cracow, Poland, pp. 95-110, 2008.
- [8] J. Greenwood and J. Williamson, 'Developments In The Theory of Surface Roughness', in: *Proc. 4th Leeds-Lyon Symp. On Tribology*, D. Dowson Et Al.[Eds.], Mechanical Engineering Publications, London, pp. 167-177, 1977.
- [9] N. Patir and H.S. Cheng, 'An Average Flow Model For Determining Effects of Three-Dimensional Roughness on Partial Hydrodynamic Lubrication', *Journal of Lubrication Technology*, vol. 100, no. 1, pp. 12-17, 1978.

- [10] N. Patir and H. Cheng, 'Application of Average Flow Model to Lubrication Between Rough Sliding Surfaces', *Journal of Lubrication Technology*, vol. 101, no. 2, pp. 220-229, 1979.
- [11] A. Yamaguchi and H. Matsuoka, 'A Mixed Lubrication Model Applicable to Bearing/Seal Parts of Hydraulic Equipment', *Journal of Tribology*, vol. 114, no. 1, pp. 116-121, 1992.
- [12] T. Kazama and A. Yamaguchi, 'Application of a Mixed Lubrication Model for Hydrostatic Thrust Bearings of Hydraulic Equipment', *Journal of Tribology*, vol. 115, no. 4, pp. 686-691, 1993.
- [13] T. Kazama and A. Yamaguchi, 'Experiment on Mixed Lubrication of Hydrostatic Thrust Bearings for Hydraulic Equipment', *Journal of Tribology*, vol. 117, no. 3, pp. 399-402, 1995.
- [14] A. Majumdar and B. Bhushan, 'Role of Fractal Geometry in Roughness Characterization and Contact Mechanics of Surfaces', *Asme J. Tribol*, vol. 112, no. 2, pp. 205-216, 1990.
- [15] J.L. Liou, C.M. Tsai and J.-F. Lin, 'A Micro Contact Model Developed for Sphere-And Cylinder-Based Fractal Bodies in Contact with a Rigid Flat Surface', *Wear*, vol. 268, no. 3, pp. 431-442, 2010.
- [16] J.M. Bergada, D.L. Davies, S. Kumar and J. Watton, 'The Effect of Oil Pressure and Temperature on Barrel Film Thickness and Barrel Dynamics of an Axial Piston Pump', *Meccanica*, no. 47, pp. 639-654, 2012.
- [17] W. Hong, S. Wang and M. Tomovic, 'A Hybrid Method Based on Band Pass Filter and Cooreation Algorithm to Improve Debris Sensor Capacity', *Mechanical Systems And Signal Processing*, no. 82, pp. 1-12, 2017.